



WEATHERFLO® HD

- **Comprehensive solution** for housing VFDs includes integrated cooling via high-performance, shielded impellers
- **Flexible back panel design** facilitates horizontal or vertical panel installation from the rear, allowing easier and safer installation by fewer people
- **Robust construction** supports up to 500 HP VFDs in extreme outdoor applications



Please contact your CBT Specialist for more information at 513-621-9050.

Cincinnati
 737 W 6th Street
 Cincinnati, OH 45203
 513-621-9050

Springboro
 130 Advanced Drive
 Springboro, OH 45066
 937-746-7356



WEATHERFLO® HD

Rugged protection and integrated cooling for up to 500 HP VFDs.

Ensure sustained operation of your heavy-duty variable frequency drives (VFDs) in harsh outdoor environments with the Hoffman WEATHERFLO® HD solution from Pentair Technical Products. Forget the hassle of designing a custom solution to house VFDs, adding cooling and hoping the solution will withstand precipitation, debris, animals and more. WEATHERFLO HD is the first comprehensive solution designed specifically to house VFDs in extreme environments—from irrigation pumps to HVAC and general industrial drives.

Featuring shielded impellers to keep dust out of bearings, stainless steel mesh screens on the top and base to keep out animals and debris, and robust aluminum construction, WEATHERFLO HD withstands elements—in the short and long term. Designed for simple installation. Engineered for robust protection and minimal maintenance. Feature rich and tested to the extreme in Hoffman's UL certified test lab. WEATHERFLO HD offers the most complete assembled solution for meeting the demands of heavy-duty VFDs in challenging applications across the globe.

WEATHERFLO Solutions

WEATHERFLO HD is the latest addition to the WEATHERFLO family of enclosures. These enclosures provide a proven solution featuring a forced-air ventilation system for cooling drives or other high-heat producing equipment in outdoor applications. For more information on the complete line of WEATHERFLO products, visit hoffmanonline.com

APPLICATIONS:

- Irrigation
- Pulp and paper
- Water and wastewater
- Oil and gas
- Mining and boring
- HVAC



FEATURES AND BENEFITS:

- **Integrated cooling:** Optional accessory impeller packages provide 840 actual CFM of exhaust airflow per impeller
- **Flexible back panel mounting** options for easier and safer installation
- **Rugged protection** for 100 to 500 HP VFDs
- **UL Type 3R certified:** Tested for reliable protection in extreme conditions
- **Versatile options:** One- or two-door models available; selectable bases, covers and tops
- **Customizable:** Provisions for ganging multiple enclosures together in large applications
- **White paint** for low solar absorption

Two simple back-panel loading options:

Populated back panel is mounted from the rear of the enclosure

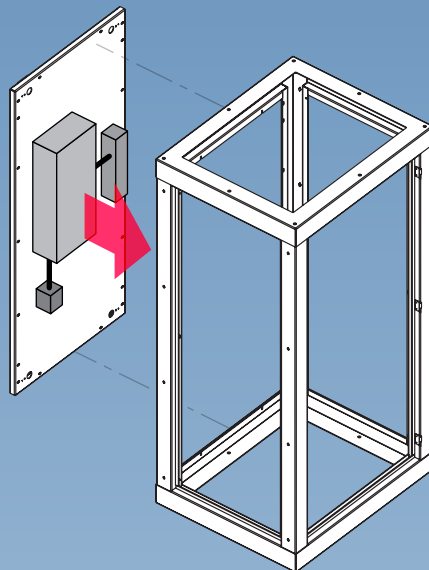

Frame can be lowered onto the populated back panel

